



DIAMOND DRESSERS



EHWA DIAMOND INDUSTRIAL CO., LTD.

520-2, Won-dong, Osan-city, Gyeonggi-Do, Korea (447-804)
<http://www.ehwadia.com> / e-mail : bkim@ehwadia.co.kr
Tel : +82-(31) 370-9220 / Fax : +82-(31) 374-9840



DIAMOND DRESSERS

INNOVATOR IN TECHNOLOGY

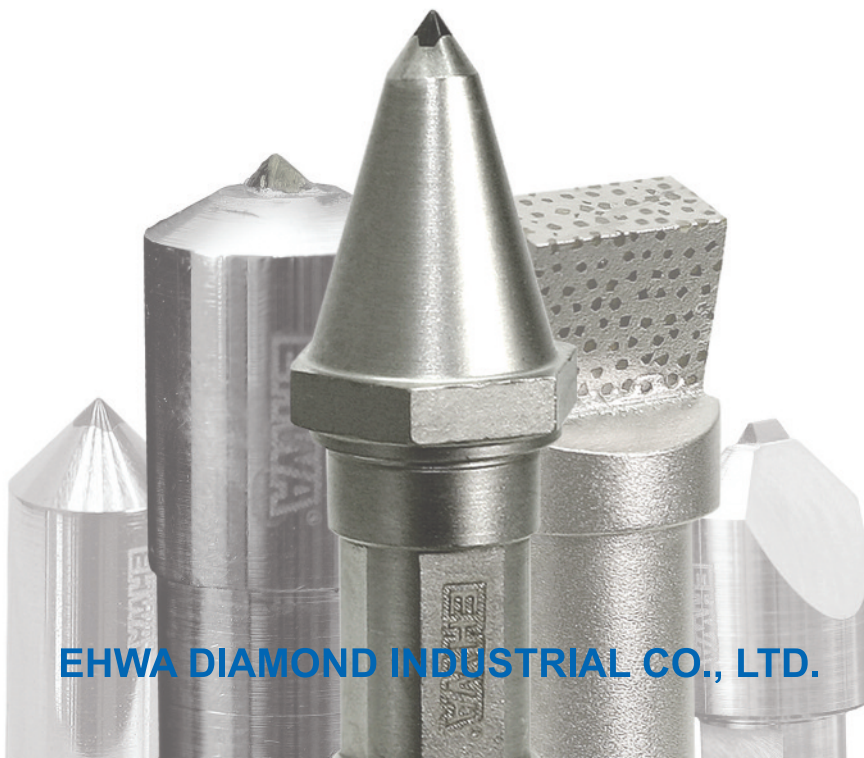

EHWA DIAMOND INDUSTRIAL CO., LTD.

EHWA DIAMOND

Since 1975, Ehwa Diamond has been growing rapidly by developing long-term partnerships with customers worldwide and continues to strive towards excellence in providing the very best customer satisfaction through product innovation and improvements.

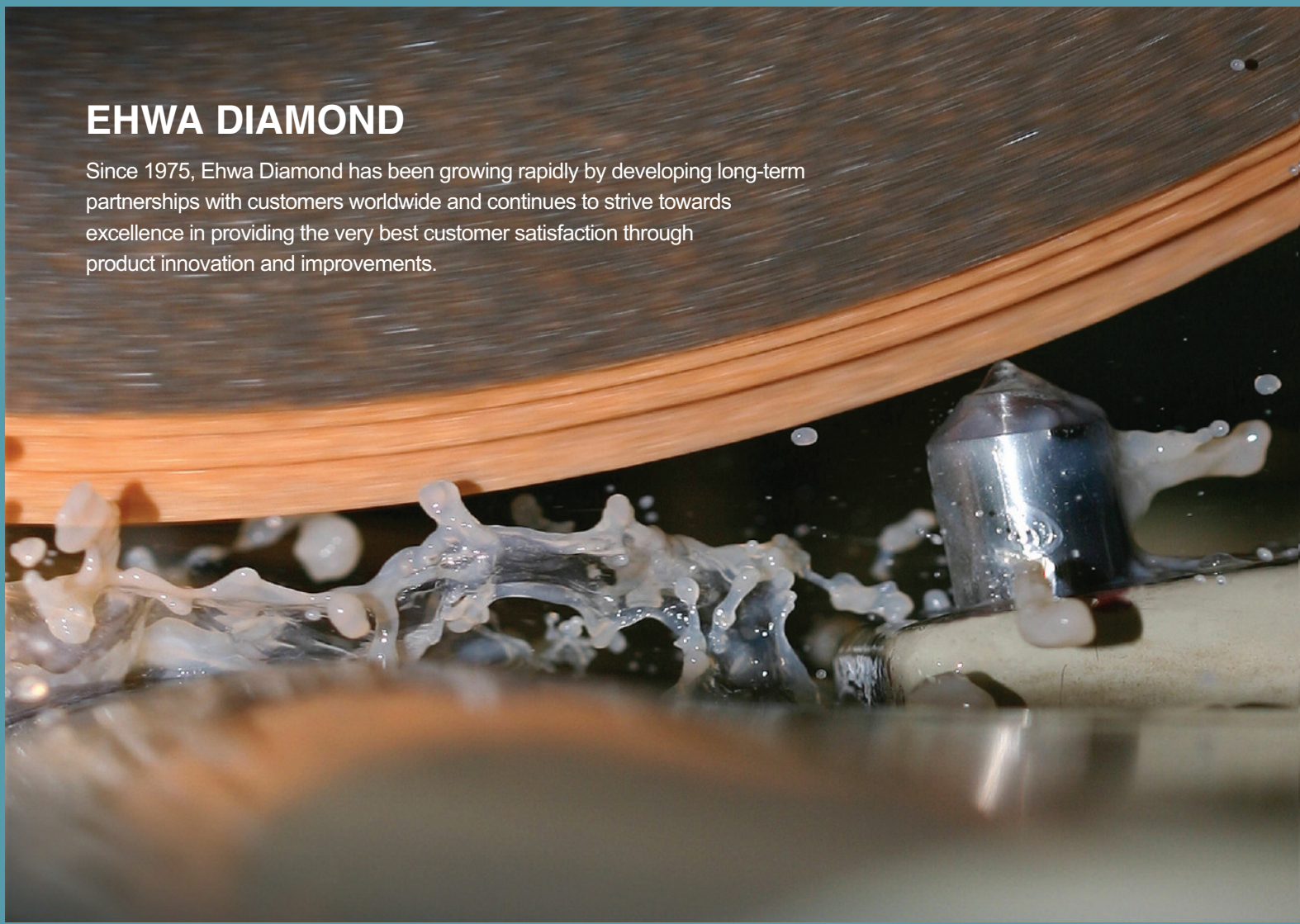

INNOVATOR IN TECHNOLOGY

DIAMOND DRESSERS



SDD (Single-point Diamond Dressers)

Manufactured by sintering a selected diamond crystal with metal matrix into a steel shank.

FDD (Forming Diamond Dressers)

Manufactured by shaping a selected high-quality diamond.

MDD (Multi-point Diamond Dressers)

Two or more selected diamonds are set in metal matrix.

IDD (Impregnated Diamond Dressers)

Manufactured by sintering selected diamond particles with metal matrix.

PCD dressers

Manufactured by brazing Poly-crystalline diamonds.



Contents

Materials -----	4
Comparison chart by material -----	5
SDD (Single-point Diamond Dressers) ----- (Natural / Synthetic)	6
FDD (Forming Diamond Dressers) ----- (Roof / Chisel / Cone)	9
MDD (Multi-point Diamond Dressers) ----- (Natural / Blade types)	12
IDD (Impregnated Diamond Dressers) ----- (Non-patterned IDD / Patterned IDD)	16
Special tools ----- (Burnishing tools / PCD / Contact gauges)	18

Applications	Diamond dressers
<ul style="list-style-type: none"> Used for straight type conventional abrasive wheels. Used for simple profile, thread and gear grinding abrasive wheels. 	SDD, IDD
<ul style="list-style-type: none"> Used for straight type and conventional abrasive profile wheels. Able to dress complex forms and profiles with precision. 	FDD, MDD
<ul style="list-style-type: none"> Ideal for dressing larger and wider conventional abrasive wheels. Used for dressing conventional surface and center-less abrasive wheels. 	MDD, IDD
<ul style="list-style-type: none"> Used for dressing complex forms and profiles. 	PCD dressers

Expression of EWHA diamond dressers





Materials

Synthetic diamonds

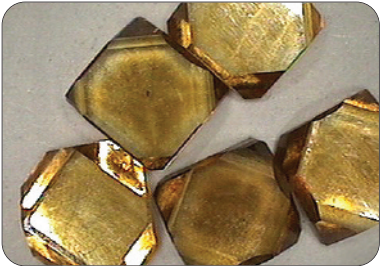

F: MONO CRYSTAL

Almost same property as natural diamond
Applications : SDD, FDD

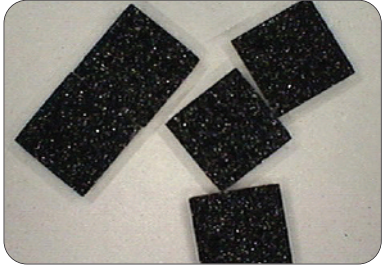

G: CVD (Chemical Vapor Deposition)

Applications : SDD, FDD, MDD

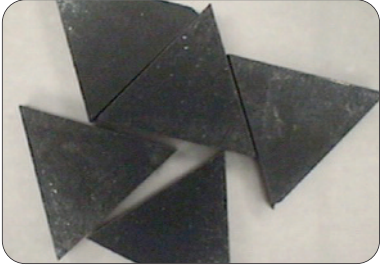

H: PCD

Applications : PCD dresser

Natural diamonds



A: OCTAHEDRON

Point angle 90 degree / Applications :
SDD, Natural diamond-MDD



B: DODECAHEDRON

Point angle 120 degree / Applications :
SDD, Natural diamond-MDD



C: ELONGATED

Oblong shape
Applications : FDD cone type



D: MACCLE

Triangle shape
Applications : FDD chisel type



E: SHAPE

Round, Flat shape
Applications : FDD chisel type



Comparison chart by material

Property	Natural Diamond	Mono Crystal	CVD Diamond	PCD	WC (K10)
Thermal conductivity (W/mK)	2000	2000	1000	560	110
Hardness (GPa)	50~100	50~100	80~100	50	18
Toughness (MPam-m ^{1/2})	3.4	3.4	5~6	8~9	10.5
Tensile strength (Gpa)	1000~3000	1000~3000	400~800	1260	-
Compressive strength (Gpa)	9	9	16	7.6	6.1
TRS (Gpa)	2.9	2.9	1.3	1.2	2.4

● Recommended diamond dresser by wheel shape ●

Straight

SDD, MDD, IDD

Tapered

SDD, MDD, IDD

Convex

SDD, FDD, MDD

Concave

FDD, MDD

Angled

FDD, MDD

Multi-angled

FDD, MDD



DIAMOND DRESSER

SDD

Single-point
Diamond Dresser



S Single-point diamond dressers :

Single-point diamond dressers are versatile and economical to dress straight type conventional abrasive wheels. Customers can choose diamond carat and materials dependent upon working conditions such as wheels size, wheel width, depth of cut, etc.

Recommended Depth of Cut :

Wheel grit size 20~60 : 0.025 mm ~ 0.05 mm

Wheel grit size 80~140 : 0.015 mm ~ 0.025

Wheel grit size 160~200 : 0.01 mm ~ 0.015

Recommended Diamond Carat :

Wheel Diameter 100~150 : 1/7 ct

Wheel Diameter 175~250 : 1/5 ct

Wheel Diameter 300~350 : 1/4 ct

Wheel Diameter 350~400 : 1/3 ct

Wheel Diameter 400~500 : 1/2 ct

Wheel Diameter 500~600 : 3/4 ct

Wheel Diameter 600~ : 1 ct





Natural

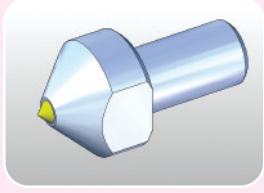

Available diamond :

- A (Octahedron)
- B (Dodecahedron)

Available carat :

Max 1 ct ~ Min 1/30 ct

Synthetic

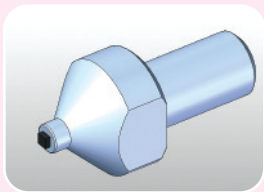

Available diamond :

- F (Mono Crystal)
- G (CVD)

Available size :

- 0.6 mm X 0.6 mm X 3 mm
- 0.8 mm X 0.8 mm X 3 mm
- 1.0 mm X 1.0 mm X 3 mm
- 1.5 mm X 1.5 mm X 3 mm

Specifications

● SDD-A01 ●

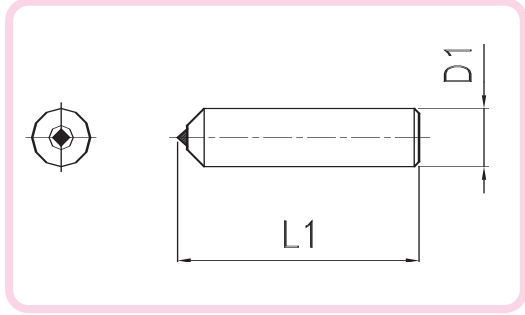

	D1	L1
Standard	12	90

● SDD-A02 ●

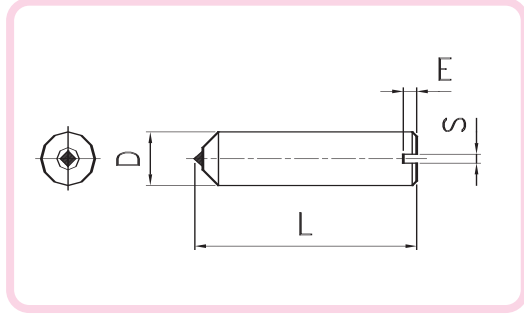

	L	D	S	E
Standard	50	10	1.5	2

● SDD-A03 ●

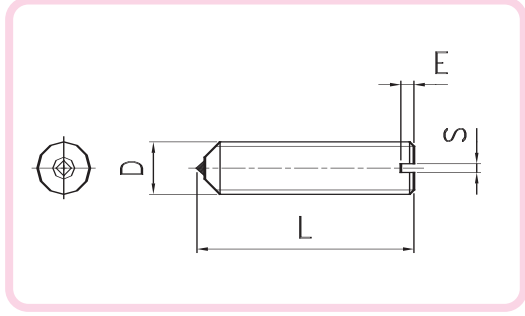

	Pich	L	S	E
Standard	M8X1.0	16	1.0	2

● SDD-A09 ●

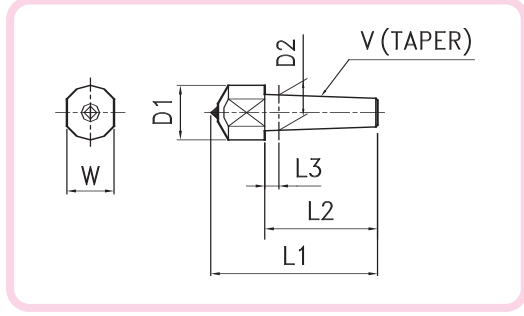

	D1	L1	L2	D2	V
Standard	18	60	42	12	MT1

Specifications

● SDD-A10 ●

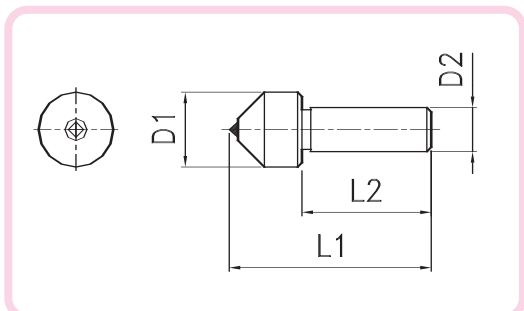

	D1	D2	L1	L2
Standard	12	8	42	25

● SDD-A12 ●

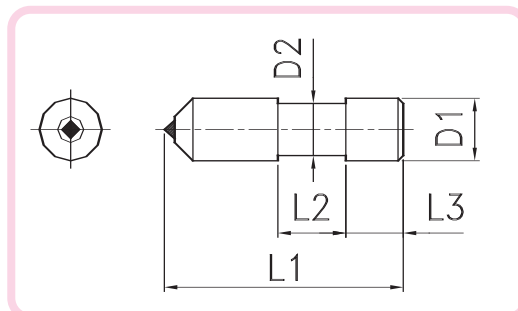

	D1	D2	L1	L2	L3
Standard	10	8	43	22	8

● SDD-A13 ●

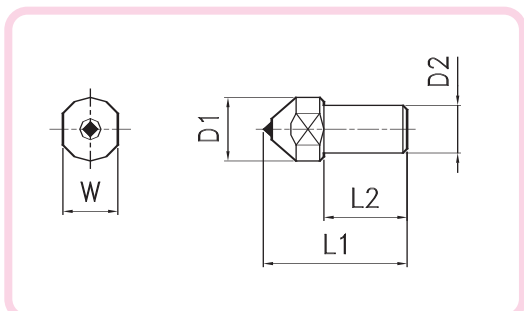

	D1	D2	L1	L2	W
Standard	16	11	37	22	14

● SDD-A14 ●

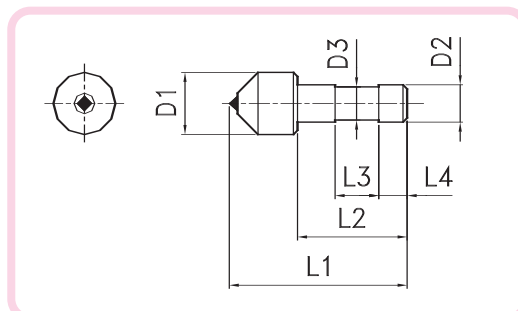

	D1	D2	D3	L1	L2	L3
Standard	16	11	8	34	19	8

● SDD-A18 ●

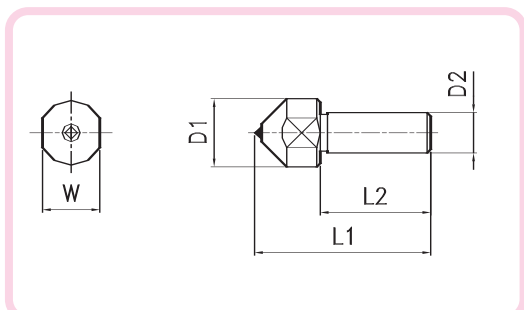

	D1	D2	L1	L2	W
Standard	16	11	29	15	14



DIAMOND DRESSER

FDD

Forming
Diamond Dresser



F

Forming Diamond Dressers :

Forming diamond dressers are used for dressing specific forms into conventional abrasive wheels requiring longer tool life.

Natural diamonds have very high resistance while they could be easily broken and have unsteady tool life. On the other hand, synthetic diamonds have steady tool life. Generally, the bigger radius of diamonds can ensure longer tool life. However, the much bigger radius can get grinding wheels to be burned because it makes the grinding wheels' grit blunt.

Recommended angle and radius (For chisel dresser)

Rough grinding : R 0.3~0.5, 50° ~ 60°

Finish grinding : R 0.1~0.25 , 30° ~ 45°



Roof

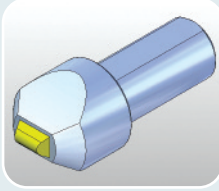

Available diamond :
D (Maccle), E (Shape),
F (Mono crystal),
G (CVD), H (PCD)

Available carat :
Max 3/4 ct ~ Min 1/4 ct

Chisel

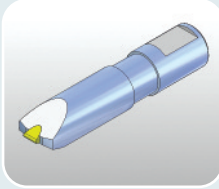

Available diamond :
D (Maccle), E (Shape),
F (Mono crystal),
G (CVD)

Available carat :
Max 3/4 ct ~ Min 1/4 ct

Cone

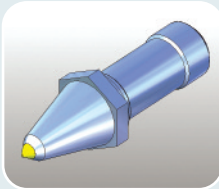

Available diamond :
C (Elongated),
G (CVD)

Available carat :
Max 1/2 ct ~ Min 1/4 ct

Specifications

● FDD-C01 ●

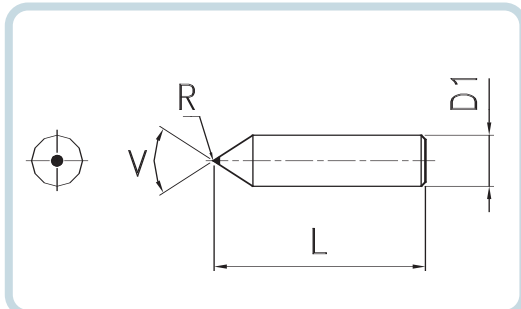

	D1	L	V	R
Standard	11	30	90	0.3

● FDD-C13 ●

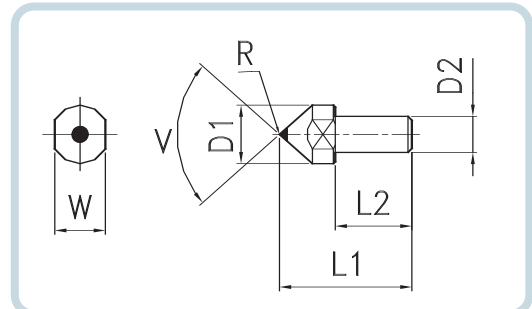

	D1	D2	L1	V	R
Standard	15	11	23	90	0.3

● FDD-C14 ●

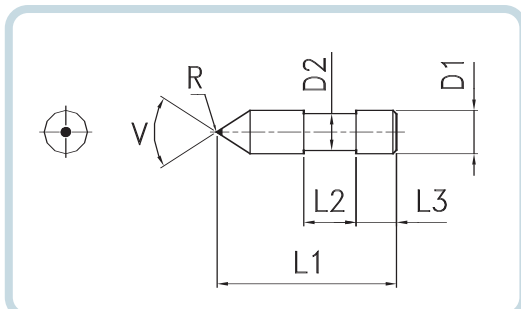

	D1	D2	L1	V	R
Standard	10	8	43	90	0.3

● FDD-C19 ●

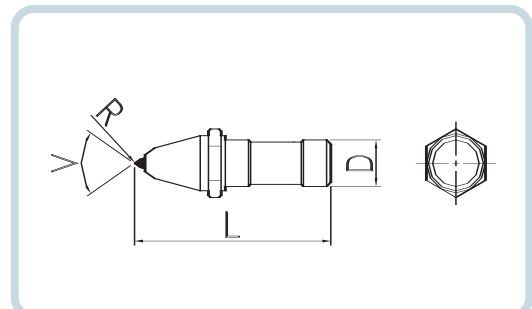

	D	L	V	R
Standard	11	46.5	70	0.3



● FDD-D01 ●

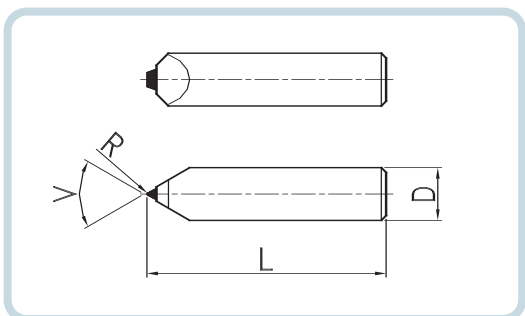

	D	L	V	R
Standard	11	40	55	0.2

● FDD-D12 ●

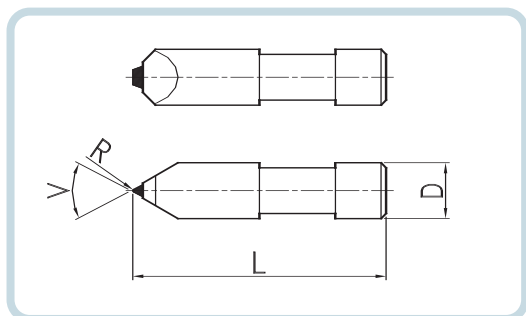

	D	L	V	R
Standard	10	45	55	0.2

● FDD-D05 ●

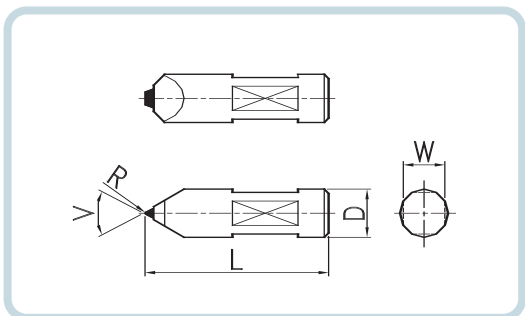

	D	L	w	V	R
Standard	11	45	9	55	0.2

● FDD-D14 ●

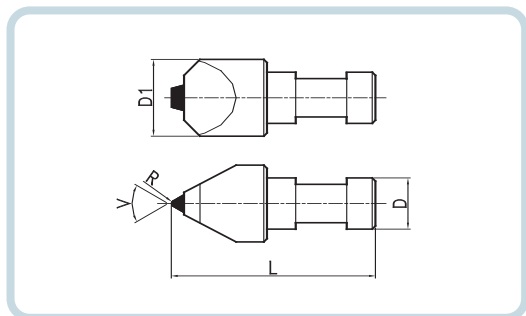

	D1	D	L	V	R
Standard	12	8	32	55	0.2

● FDD-D17 ●

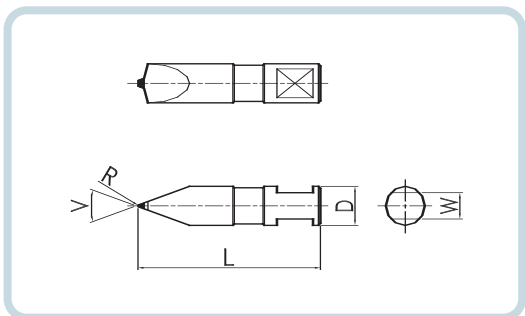

	D	L	W	V	R
Standard	9.5	44.5	6	40	0.25

● FDD-D19 ●

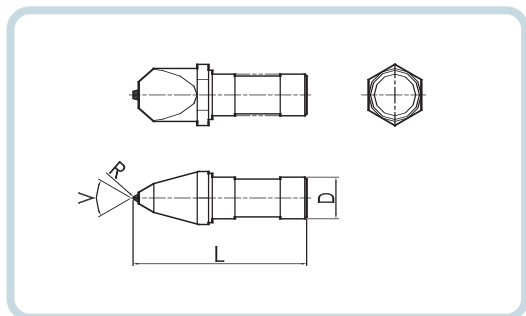

	D	L	V	R
Standard	11	46	60	0.3

● FDD-D20 ●

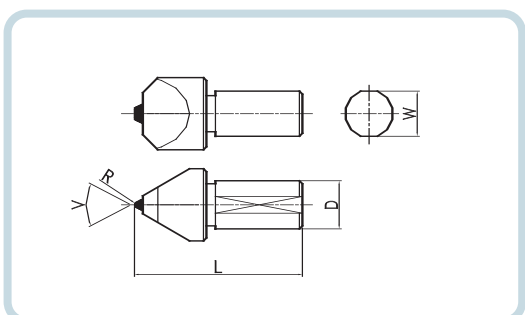

	D	L	V	R
Standard	8	29	55	0.2

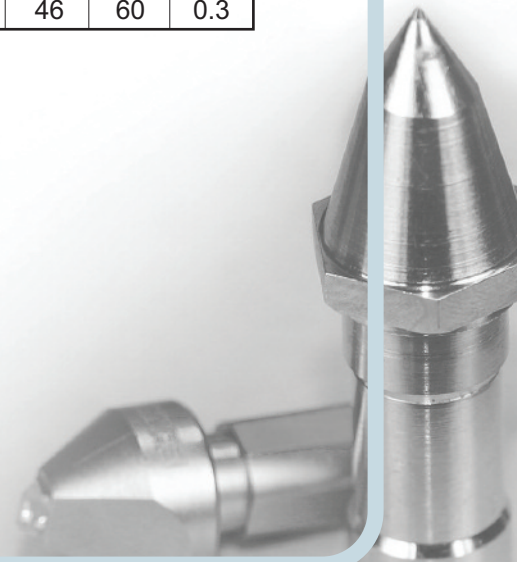



DIAMOND DRESSER

MDD

Multi-point
Diamond Dresser

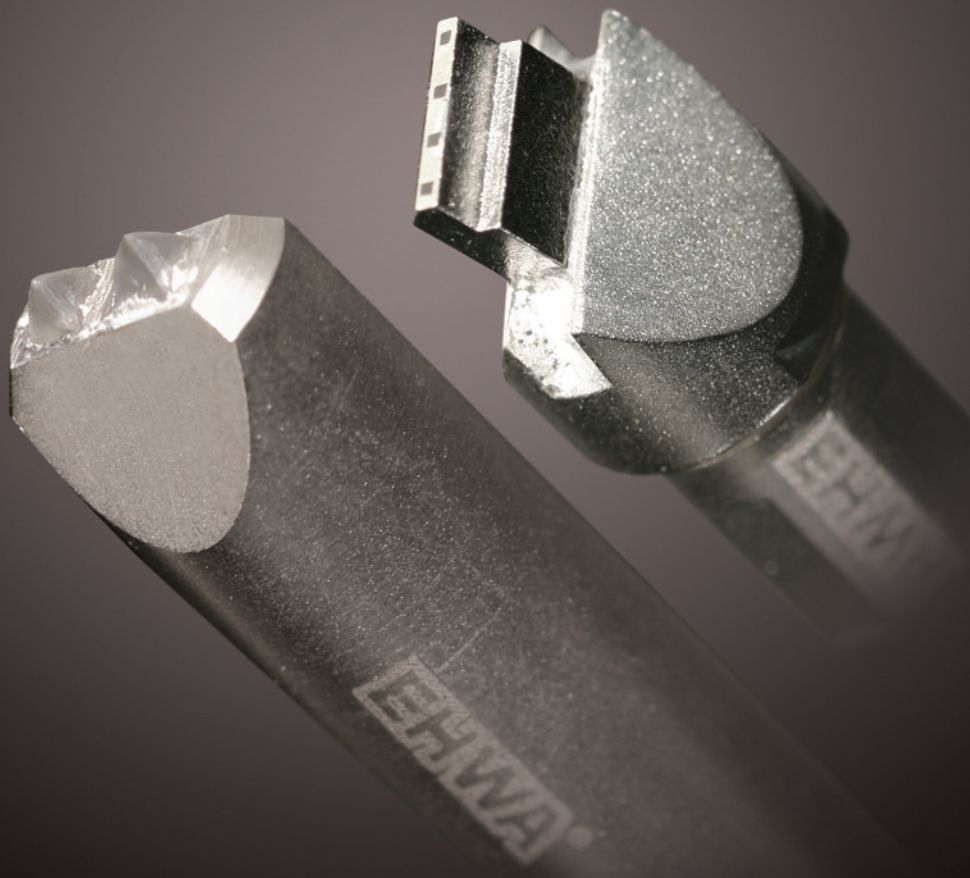

Multi Diamond Dressers :

Two or more selected diamonds are set in a metal matrix to provide multi diamond points for dressing larger and wider conventional abrasive wheels. Multi-point diamond dressers have two types. One is a general type for dressing straight type conventional abrasive wheels; the other a blade type for dressing larger and conventional abrasive profile wheels at lower cost.

Multi-point diamond dressers using diamonds made by chemical vapor deposition are suited to get high quality surface finish and consistent performance. On the other hand, multi-point diamond dressers made of elongated natural diamonds, which is called "Fliesen tool", have longer tool life.





Natural

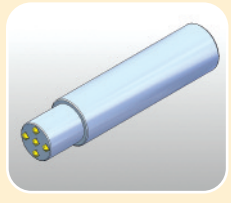

Available diamond :
A (Octahedron),
B (Dodecahedron)

Available carat :
Max 1/3 ct ~ Min 1/30 ct

Blade type

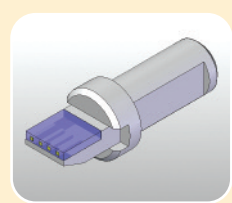
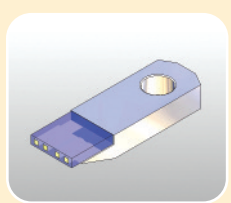

Available size :
CVD 0.4 mm X 0.4 mm X 5 mm
CVD 0.6 mm X 0.6 mm X 5 mm
CVD 0.8 mm X 0.8 mm x 3 mm
CVD 0.8 mm X 0.8 mm X 6 mm
CVD 1.0 mm X 1.0 mm X 3 mm
Elongated 1/20 ct ~ 1/80 ct

Specifications

● MDD-A01 ●

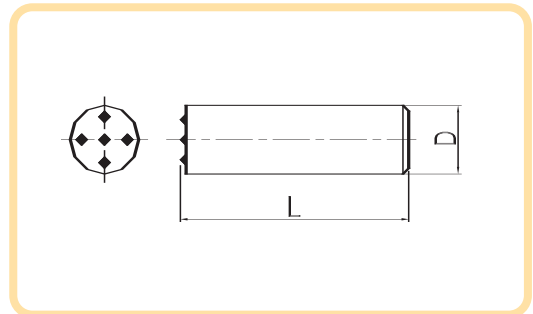

	D	L
Standard	11	40

● MDD-A05 ●

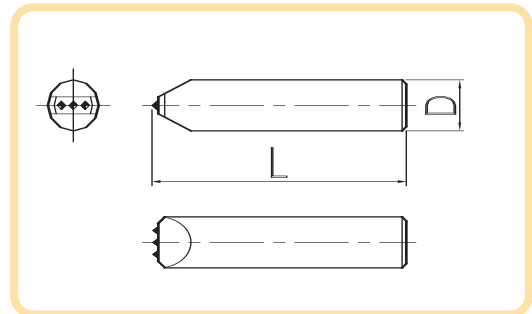

	D	L
Standard	11	40

● MDD-A09 ●

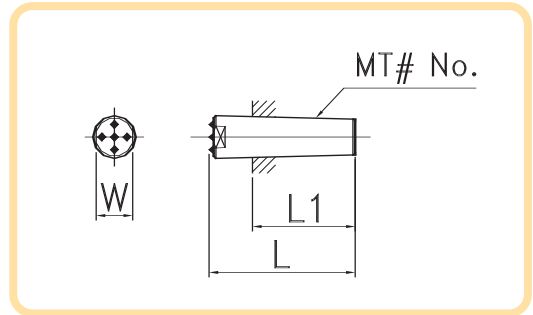

	L	L1	W	Taper
Standard	32	22	8	MT#No.1

● MDD-A10 ●

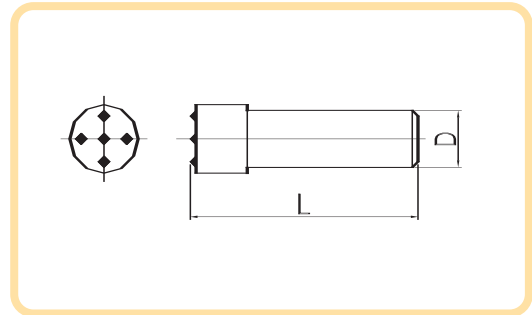

	D	L
Standard	11	29

Specifications

● MDD-G11 ●

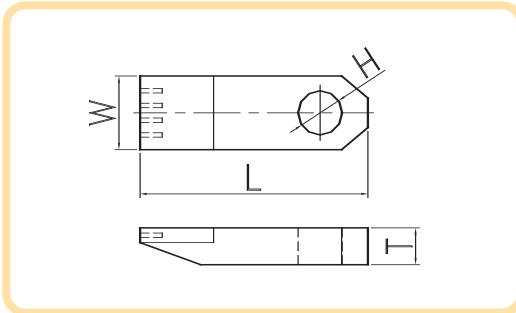

	L	T	W	H
Standard	28	5	10	6.1

● MDD-G12 ●

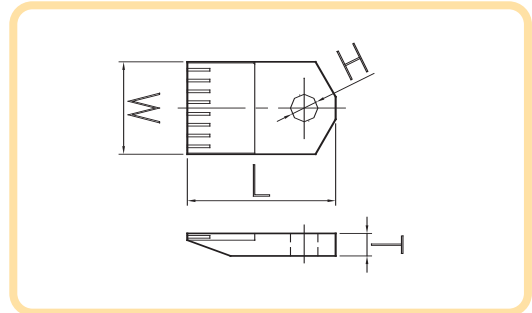

	L	T	W	H
Standard	33	5	20	6.1

● MDD-G13 ●

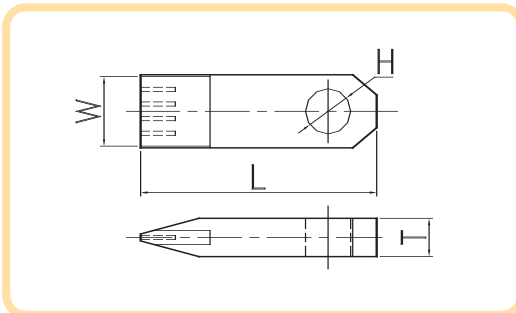

	L	T	W	H
Standard	28	5	10	6.1

● MDD-G14 ●

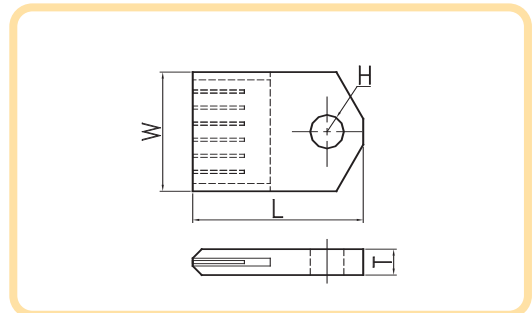

	L	T	W	H
Standard	33	5	20	6.1

● MDD-G21 ●

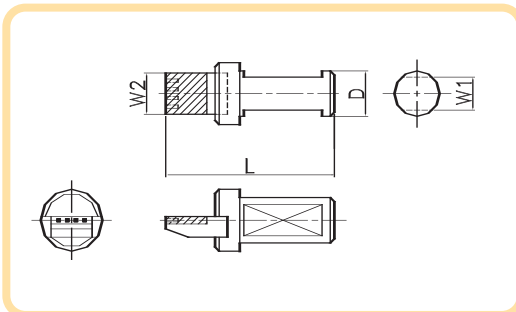

	D	L	W1	W2
Standard	11	41	8	10

● MDD-G22 ●

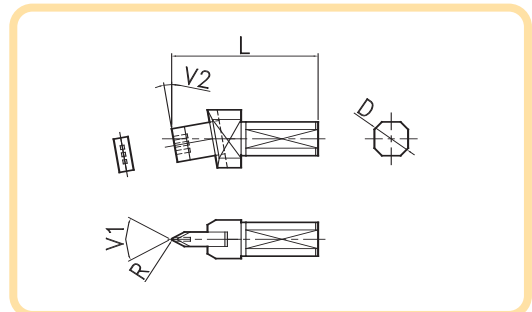

	D	L	V1	V2	R
Standard	8	29	55	10	0.3



● MDD-G23 ●

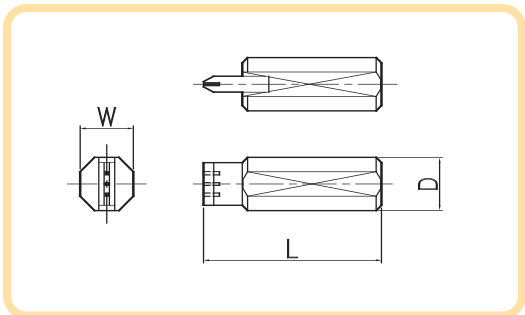

	D	L	W
Standard	11	33	10

● MDD-G24 ●

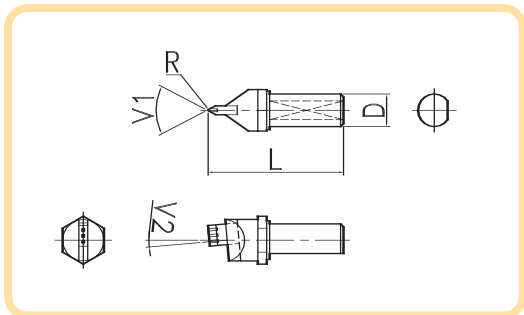

	D	L	V1	V2	R
Standard	11	46	55	5	0.3

● MDD-C12 ●

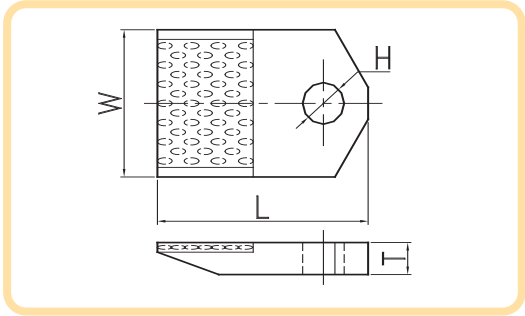

	L	T	W	H
Standard	28	5	20	6.1

● MDD-C14 ●

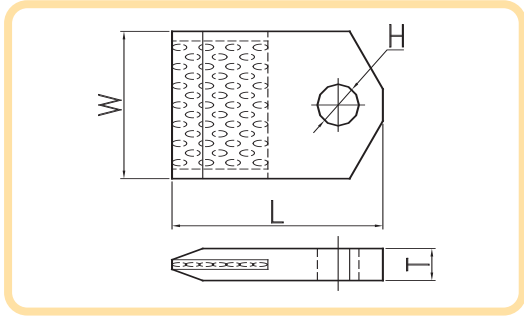

	L	T	W	H
Standard	33	5	20	6.1

● MDD-B13 ●

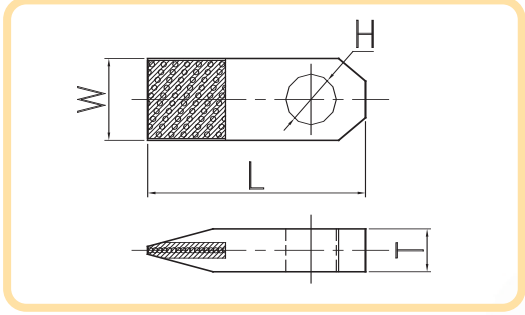

	L	T	W	H
Standard	28	5	10	10

● MDD-B12 ●

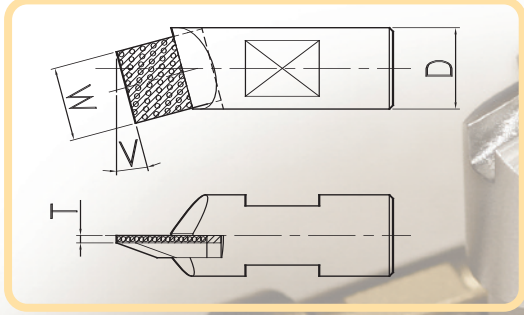

	D	W	V	T
Standard	8	10	15	1.5



DIAMOND DRESSER

IDD

Impregnated
Diamond Dresser

ZENESIS® TECHNOLOGY

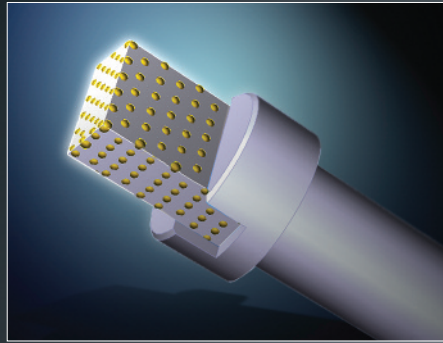

Impregnated Diamond Dressers :

Impregnated diamond dressers have tiny diamond particles bonded in metal matrix. Dressing force is spread across the fine diamonds; impregnated diamond dressers can achieve longer tool life at lower cost.

Randomly distributed impregnated diamond dressers cannot optimally show their performance as required. That is why Ehwa has developed patterned impregnated diamond dressers manufactured with **ZENESIS®** technology for dressing with precision.

ZENESIS® IDD

(Patterned Impregnated Diamond Dresser)
Patent no. 10-0428947 / US 6626167

- Suitable for longer tool life and better performance
- Available mesh : # 20 ~ # 60

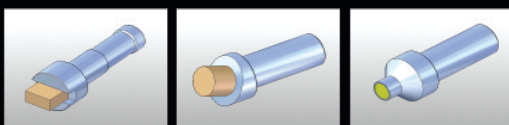

Impregnated Diamond Dresser

- Used for economical dressing
- Available mesh : #20 ~#140



Specifications

● IDD-S01 ●

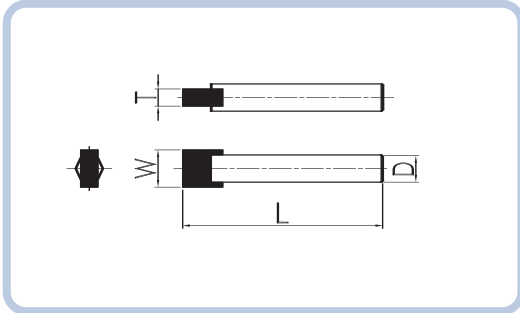

	D	L	W	T
Standard	11	70	13	6

● IDD-S03 ●

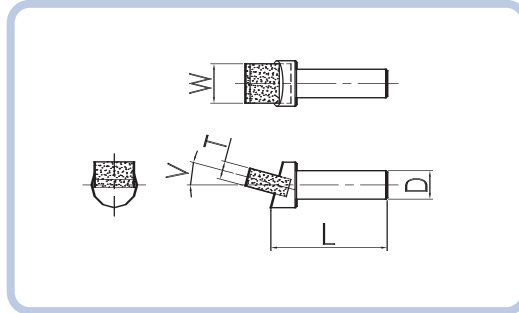

	D	L	W	T	V
Standard	11	38	13	6	15

● IDD-S04 ●

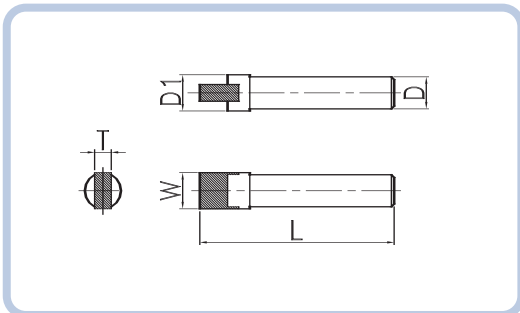

	D	D1	L	W	T
Standard	11	14	70	13	6

● IDD-S05 ●

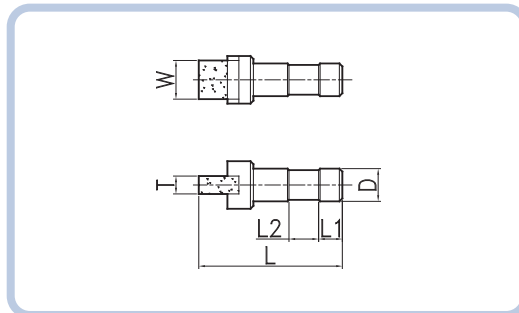

	D	L	L1	L2	W	T
Standard	11	50	7	10	13	6

● IDD-R01 ●

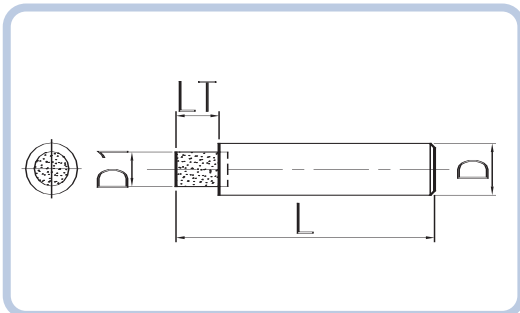

	D	D1	L	LT
Standard	11	9	40	8

● IDD-R03 ●

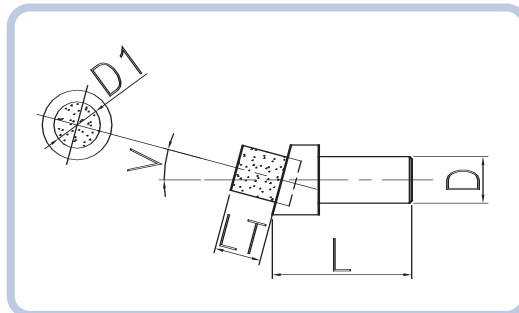

	D	D1	L	LT	V
Standard	11	9	38	8	15

● IDD-R04 ●

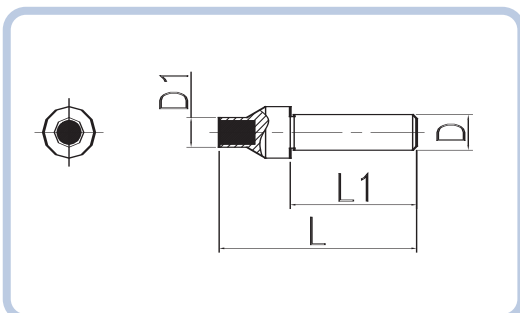

	D	D1	L	L1
Standard	11	10	40	24

● IDD-R05 ●

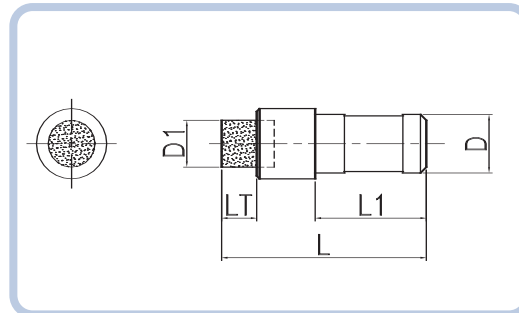

	D	D1	L	L1	LT
Standard	11	9	40	24	8

Burnishing tools

Burnishing tools are manufactured by natural or mono crystalline diamonds. The burnishing process is a cold process using proper pressure without removal of the work pieces. The burnishing tools are very useful for metalworking because they help get high quality mirror-like surface finish and meet dimensions as requested. The diamond burnishing tools can ensure longer tool life and good surface finish.

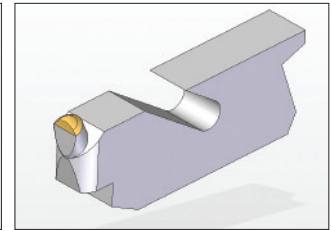
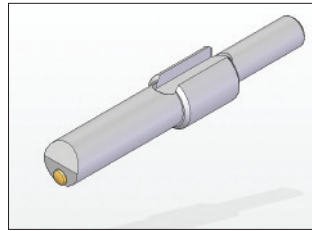

PCD (Poly-crystalline diamond) dressers

PCD dressers are cost-effective alternative in dressing conventional abrasive profile wheels. The PCD is easier to get desired shapes than the other diamond materials. As a result, PCD dressers can dress grinding wheels with complex profiles. The relatively lower tool life can be compensated by lower price.

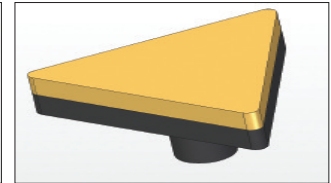
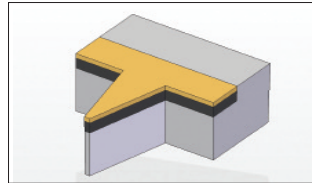
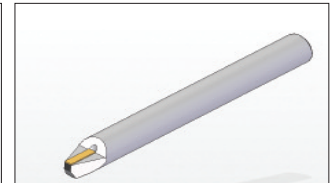
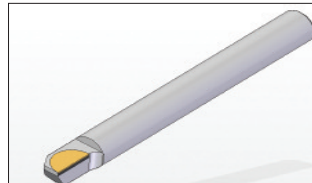

Contact gauges

Contact gauges with natural diamonds or poly-crystalline diamonds have almost 100 times longer tool life than tungsten carbides or high-speed steel. The diamond contact gauges can ensure highly accurate measurement with ultra wear resistance.

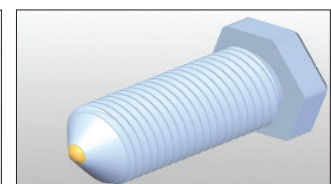
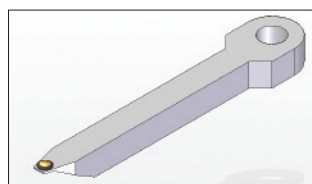
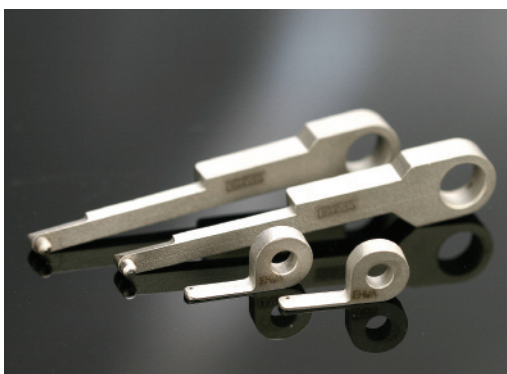



LOCATIONS

Korea



Headquarters Osan



Factory Osan (Semiconductor)



Factory Dongtan



Factory Pyungtaek



Factory Seochun



Factory Oksan

Overseas



Factory Weihai, China



Factory Shanghai, China



Factory Fujian, China



Office Nagoya, Japan



Office Ehwa Europe Frankfurt, Germany



Factory, Thailand



Office, GT, U.S.A.