

Weight: 30.7 g [0.068 lb]

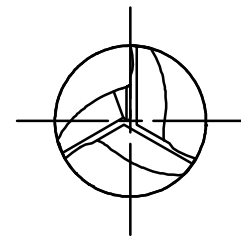
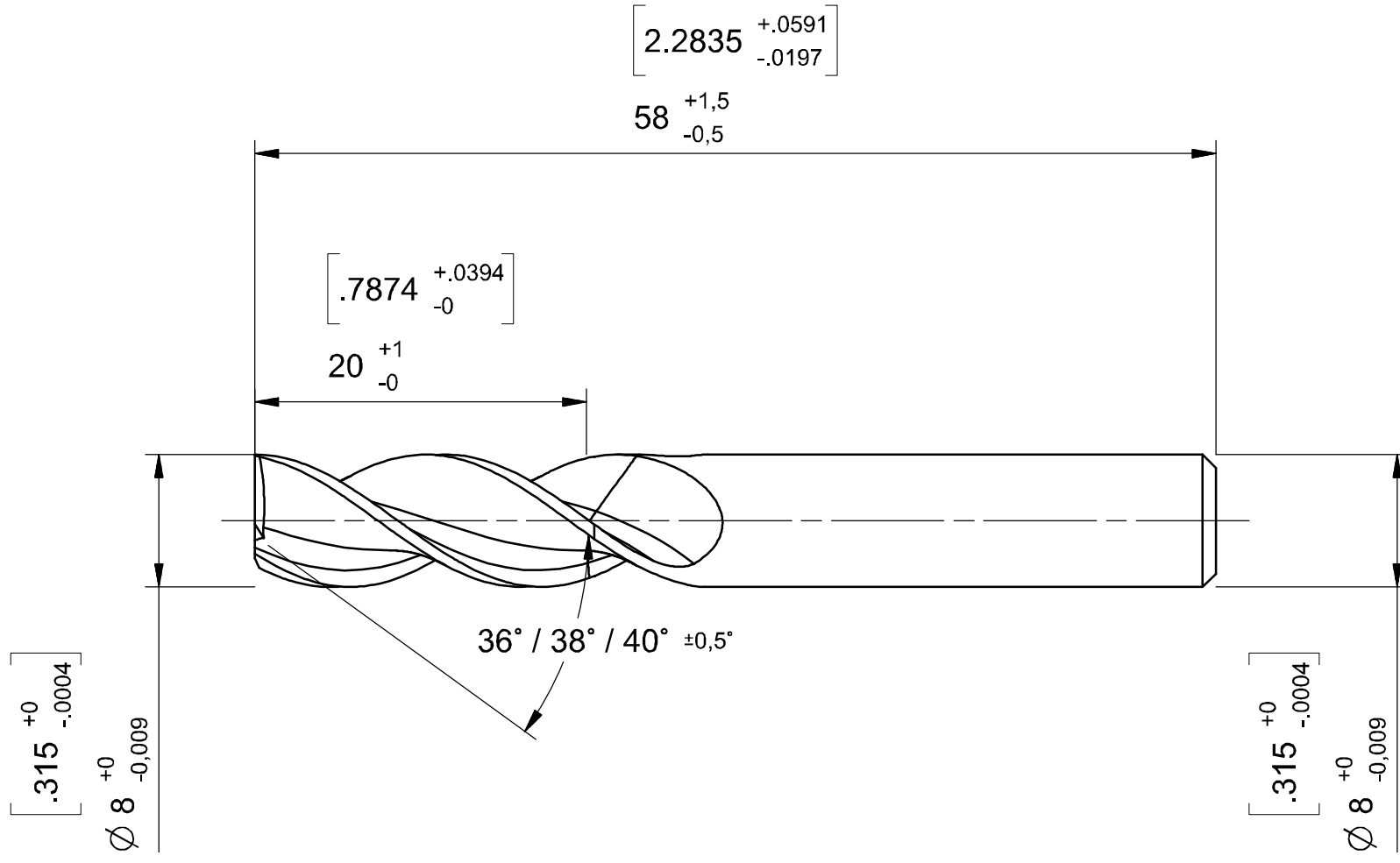

NO. OF FLUTES = 3
UNEQUAL SPACING

ER NUMBER	ER DESCRIPTION

TOLERANCES UNLESS OTHERWISE SPECIFIED													
ISO 2768 mK													
MM	OVER TO	FOR LENGTH					FOR ROUNDINGS AND CHAMFERS			FOR ANGLES - LENGTH OF SHORT LEG			
		0.5	3	6	30	120	0.5	3	6	10	10	50	120
±	±	0.1	0.1	0.2	0.3	0.5	0.2	0.5	1.0	1°	30°	20°	10°
INCH	OVER TO	0.02	0.12	0.24	1.2	4.72	0.02	0.12	0.24	0.4	0.4	1.97	4.72
		±	±	0.004	0.004	0.008	0.012	0.020	0.008	0.020	0.040	1°	30°

BREAK ALL SHARP CORNERS ON STEEL 0.5 x 45°
CHAMFER FIRST THREAD ON TAPPED HOLES

SURFACE FINISH SYMBOLS PER ISO 1302			
SYM	\sqrt{NB}	$\sqrt{N7}$	$\sqrt{N6}$
μM	$\sqrt{Ra 3.2}$	$\sqrt{Ra 1.6}$	$\sqrt{Ra 0.8}$
μIN	$\sqrt{Ra 125}$	$\sqrt{Ra 63}$	$\sqrt{Ra 32}$
SYM	$\sqrt{N5}$	$\sqrt{N4}$	$\sqrt{N3}$
μM	$\sqrt{Ra 0.4}$	$\sqrt{Ra 0.2}$	$\sqrt{Ra 0.1}$
μIN	$\sqrt{Ra 16}$	$\sqrt{Ra 8}$	$\sqrt{Ra 4}$

MATERIAL	GRADE K600
FIRST ANGLE PROJECTION	[INCHES] MILLIMETERS

NOTICE: THIS DRAWING IS THE PROPERTY OF KENNAMETAL INC. AND/OR A KENNAMETAL INC. SUBSIDIARY AND CONTAINS PROPRIETARY AND TRADE SECRET INFORMATION AND INTELLECTUAL PROPERTY RIGHTS. IT HAS BEEN SUBMITTED TO YOU IN CONFIDENCE FOR A SPECIFIC PURPOSE AND MAY ONLY BE USED FOR THAT PURPOSE. THE REPRODUCTION, DISTRIBUTION AND UTILIZATION OF THIS DRAWING, IN WHOLE OR IN PART, AS WELL AS THE COMMUNICATION OF ANY OF ITS CONTENTS TO OTHERS, WITHOUT EXPRESS WRITTEN AUTHORIZATION IS PROHIBITED. ALL RIGHTS RESERVED.



7460264
HP ALUMINUM D1=8
D=8 AP=20

Drawn	LEVYU	2026-06-04	Scale
Checked			2.5:1
Approved			

Cust. Part#
Cust. Dwg.#
Quote No.
Order No.
Reference

Type	CONCEPT	Sheet	1 of 1
DRAWING NUMBER	63490479.000	VER.	00
		DWG SIZE	A3